

Installing EFLEX



 **THE FURUKAWA ELECTRIC CO., LTD.**

Industrial Products Division,
Energy & Industrial Products Company

I. Installing EFLEX

1 Interval for Installing EFLEX

Table 1 shows the standards for intervals in both horizontal and vertical directions, considering the installation work.

Both the horizontal and vertical intervals may be reduced if straight joint Aquafit is used. (The values shown are those recommended by the manufacturer.)

Table 1

Nominal diameter of EFLEX (mm)	Horizontal and vertical interval (mm)	Horizontal and vertical interval when Aquafit is used (mm)
φ 30, φ 40, φ 50, φ 65	50	50
φ 80, φ 100, φ 125, φ 150	70	55
φ 200	100	60

2 Procedures for Installing EFLEX

EFLEX should be installed using the following procedures.

2-1. Trenching

- (1) The width of trenching is determined by the number of EFLEX laid. Consideration needs to be given to economy, and all safety procedures need to be followed to prevent landslides, at the minimum width.
- (2) 1. Burying of EFLEX at the required locations : at a depth of 0.3m or more from the ground surface (bottom surface of pavement) for cables of 7kv or less (Required locations refer to trenches of in-house facilities and general households, including factories, schools, collective housing, apartment complex, parks, and the greenbelts of expressways; general public roads are not included in the scope.)
 2. Burying depth of EFLEX along public roads : 0.8m or more from the road surface if directly beneath vehicular roads and 0.6m or more from the ground surface if directly beneath pedestrian ways.
- (3) Spread sand or good-quality soil underneath EFLEX, so it does not come into direct contact with stones and pebbles. The sand and soil should be compacted well, especially at the bottom section, to smooth out the surface. A compactor (photograph 2) may be used for efficient compacting work.
- (4) Take extra care when compacting sand and soil near the wall surface of the manhole (hand hole). If not compacted sufficiently, EFLEX could bend locally due to the soil pressure from above, which could adversely affect the cable lines.



Photograph 1
Smooth out the bottom section of the trench



Photograph 2
A compactor helps improve efficiency



2-2. Laying

EFLEX should be laid carefully in the trench so that soil, sand or water would not enter from the end mouth.

(1) EFLEX wound in a coil

Three to four workers should roll EFLEX along the trench, while holding it with their hands. Be careful not to drag the coil.

Note that if pulled without rolling, EFLEX will twist at every turn of the coil. Use of a turntable is recommended when a large quantity of EFLEX is used.

Be careful of the reactive force of EFLEX when removing ties of the coil or rolling the coil.

(2) EFLEX wound on a drum

Place the drum at the edge of the trench, position several workers in the trench and send out EFLEX from the drum in sequence while listing it.

2-3. Arrangement and Straightening

Using the gauge (made of lumber or plywood) shown below would be convenient when using several layers of EFLEX, to keep the intervals uniform.



Photograph 3

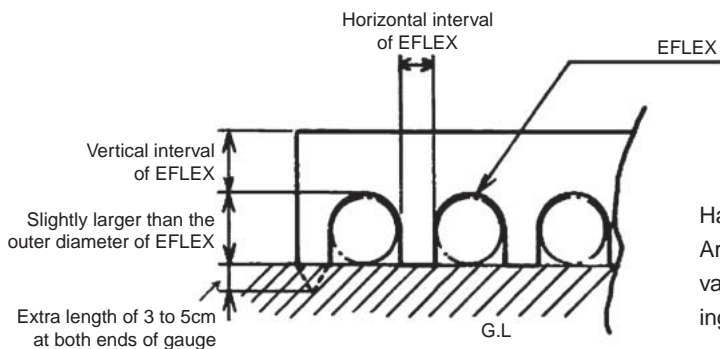

Figure 1

Have four to five gauges ready. Arrange and fit gauges from above EFLEX at intervals of about 1.5m, and straighten while maintaining mutual distance.

2–4. Provisional Filling

Backfill the trench provisionally for each tier of EFLEX while straightening, for fit. Tamp down lightly and fill with sand fully when temporarily filling. If an interval gauge is used, drop sand over the interval gauge quietly first, and fill the spaces between interval gauges with the sand. Repeat the procedure to complete temporary filling.

2–5. Passing Test Rod

Before finally backfilling the soil, pass a test rod to confirm there is no abnormality inside EFLEX and the conditions of EFLEX laid are acceptable. (See Figure 2)

The procedure is for checking the conduit beforehand, because if a defect is found in the conduit after backfilling the soil, a cable drawing could be affected and it would not be easy to correct the situation. It is recommended to pass the rod again after final backfilling of the soil, for confirmation.

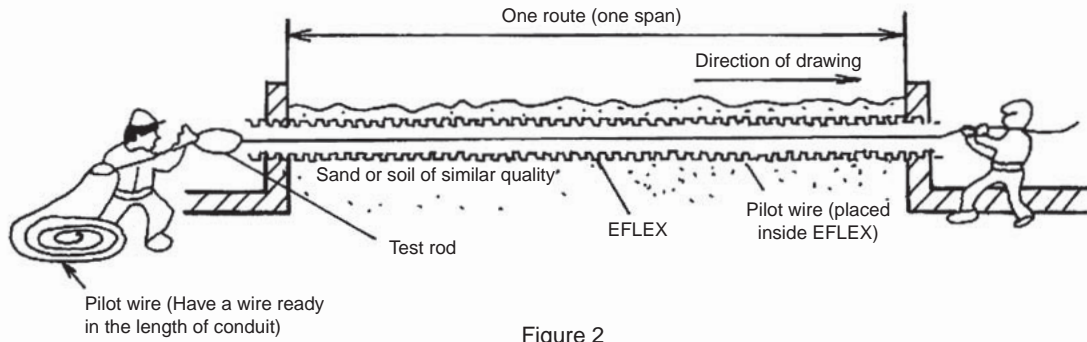

Figure 2

[Dimensions of test rod]

Table 2 shows the standard outer diameters and lengths of the test rod, to fit the size of EFLEX. If the owner has provided otherwise, follow the provisions. (Applicable for 2.5mR or larger)

Table 2

Nominal diameter of EFLEX	Test rod	
	Outer diameter (mm)	Length (mm)
φ 30	20	400
φ 40	30	400
φ 50	40	400
φ 65	55	400
φ 80	60	600
φ 100	80	600
φ 125	105	600
φ 150	130	600
φ 200	180	600

2-6. Backfilling

Backfilling is done with soil and sand for EFLEX, and for safety extra caution is required when compacting.

(1) Examples of compacting tools and machines

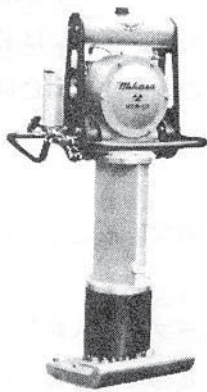

Photograph 4
Tamping rammer



Photograph 5
Vibration compactor

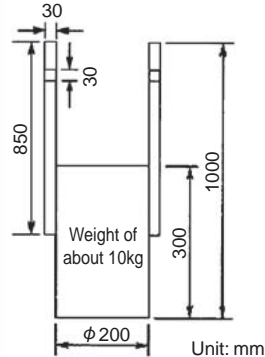

Figure 3
Wooden Club

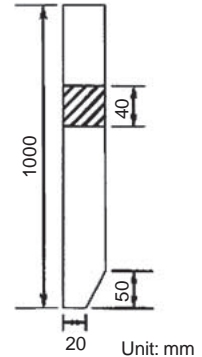
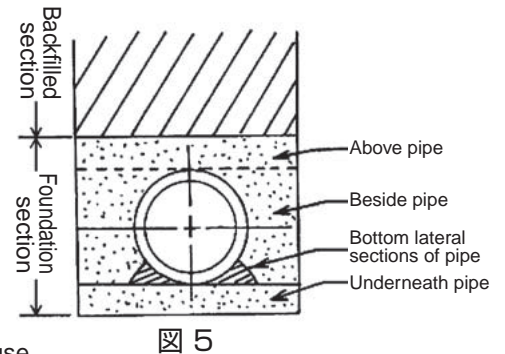

Figure 4
Tamping Rod

(2) Selection of compacting tools and machines

Table 3: Examples of Selection of Compacting Tools and Machines

Position to be compacted		Tools and machines						
		Tamping by feet	Treading by feet	Tamping rod	Wooden club	Vibration compactor	Tamping rammer	
Foundation section	Underneath pipe				○	○	○	
	Bottom lateral sections of pipe	○		○				
	Beside pipe		○		○	○*1		
	Above pipe				○	○	○	
Backfilled section					○	○	○*2	



Notes: *1 indicates the machine may be used if the trench is wide enough to use the machine.

*2 indicates that the portion immediately above the pipe is worked with a wooden club or by treading with the feet when a tamping rammer is used for the section above the pipe.

3 Finishing EFLEX Ends

3-1. Correcting Bends

A bent section may be corrected by bending in the direction opposite to the bend within the range between 30° and 45°, using a pile and others. When working with large-diameter pipes, the work may be facilitated if the pipe is heated and softened. Take care so that EFLEX is not deformed when heated. All safety procedures should also be provided.

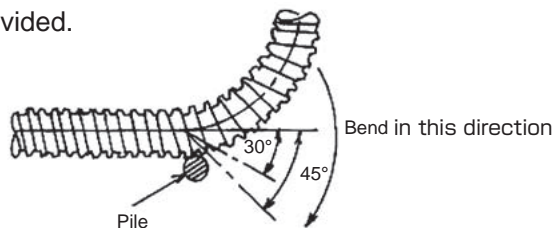

Figure 6



3 – 2. Waterproof Treatment for the Wall Surface of a Manhole (Hand Hole)

(1) Mortar filling

(i) Working with short EFLEX

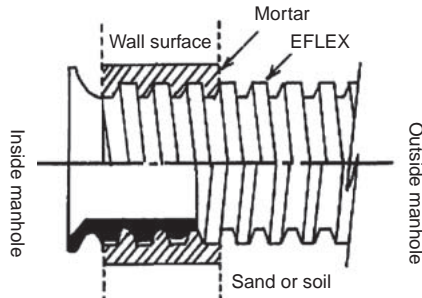

Figure 7

(ii) Working with Wall Surface Aqua

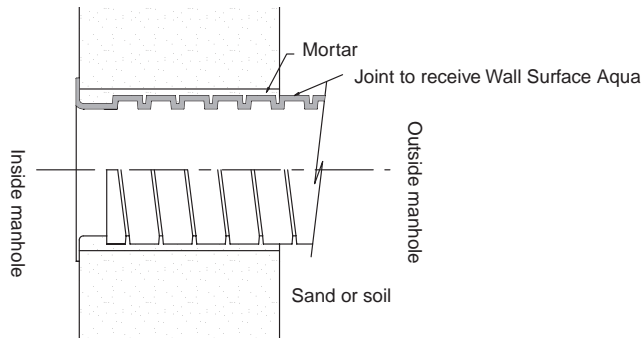

Figure 8

(2) Using both mortar and waterproof wall sealing compound

(i) When attaching EFLEX directly to manhole

(ii) When applying Wall Surface Aqua to a manhole

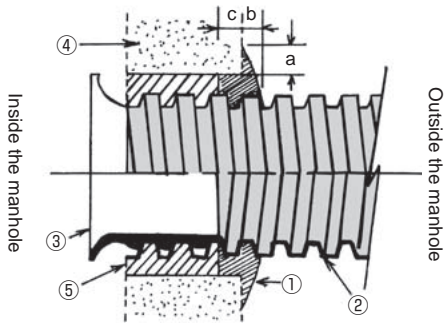

Figure 9

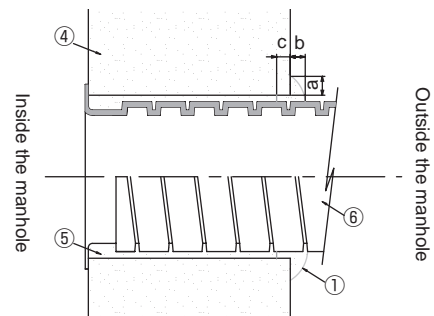

Figure 10

- (1) Waterproof wall sealing compound (epoxy putty)
- (2) EFLEX
- (3) Bellmouth
- (4) Manhole (hand hole)
- (5) Mortar
- (6) Wall Surface Aqua (joint for reception)

Table 4

Nominal diameter	a(mm)	b(mm)	c(mm)
$\phi 30 \sim \phi 100$	20	10	20
$\phi 125$ or more	20	10	30

4 Standard Construction Examples with EFLEX

4-1. Conditions for Installation

- (1) Pipe type: EFLEX
- (2) Size: ϕ 80mm
- (3) Number installed: 4 (2 tiers in 2 rows)

4-2. Procedures for Installation

As shown in Table 5.

Table 5

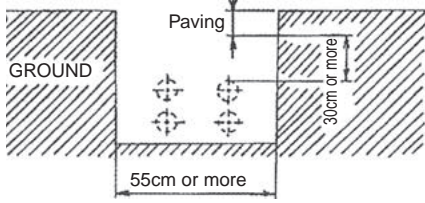
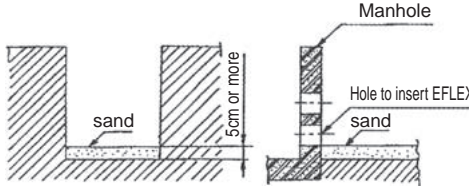
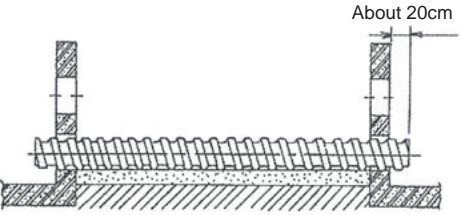
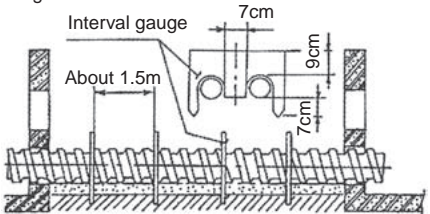
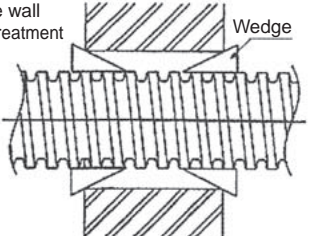
Installation diagrams	Procedures and points to note	Caution
<p>1. Trenching</p> 	<ul style="list-style-type: none"> (1) Excavate trenches carefully, so as not to let the landslide take place in the trench. (2) Place sheet piles along the trench wall surface or incline the trench as necessary. Caution is needed, especially with the soft ground. (3) Check the flatness of the trench floor visually when finishing. 	<ul style="list-style-type: none"> Install EFLEX while draining water when there is sump water. Provide sufficient safety measures when trenching.
<p>2. Sand filling and compacting</p> 	<ul style="list-style-type: none"> (1) Throw sand into the trench and level the surface. (2) Press the sand with a compactor. (3) Guidelines for completion of compacting. <ul style="list-style-type: none"> (i) Footsteps should not be left clearly. (ii) No unevenness should be visible on the finished surface. 	<ul style="list-style-type: none"> (1) Use good-quality soil in addition to sand, and avoid using sludge or waste soil containing wasted construction materials. (2) Make sure not to leave difference in levels of the insertion hole for EFLEX on MANHOLE and the floor surface after compacting.
<p>3. Piping</p> 	<ul style="list-style-type: none"> (1) Roll a coil of EFLEX on the ground to draw it out. (2) Straighten both edges of EFLEX perpendicularly after uncoiling, and lower into the trench quietly. (3) Insert the edge of EFLEX into the hole. 	<ul style="list-style-type: none"> (1) Let three or four workers hold the coil when rolling, to prevent the coil from collapsing. (2) The coil gets twisted when extended without rolling. (3) Extend the coiled <u>pilot wire</u> inside EFLEX, before unrolling it.
<p>4. Arrangement</p> 	<ul style="list-style-type: none"> (1) Fix EFLEX with interval gauges so that EFLEX would be arranged straight. (2) Fill sand around the interval gauges to fix EFLEX provisionally, and remove the interval gauges. (3) Repeat the procedures (1) and (2) from one end, over the entire length. 	<ul style="list-style-type: none"> (1) Correct the pipe if it is obviously meandering. (2) Do not use pipe saddles.
<p>5. Manhole wall surface treatment</p> 	<ul style="list-style-type: none"> (1) Make wedges from lumber and other materials, insert them between the manhole and EFLEX, so as to position EFLEX at the center. (2) Fill the gap between the manhole and EFLEX with mortar. (3) Quick-drying mortar may also be used. 	<ul style="list-style-type: none"> (1) After filling in mortar, remove the wedges and add more mortar to the spaces left by the wedges. (2) If the wall surface needs to be waterproofed, use a waterproofing wall sealing compound.

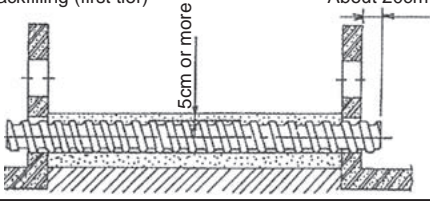
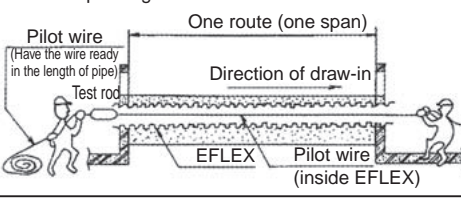
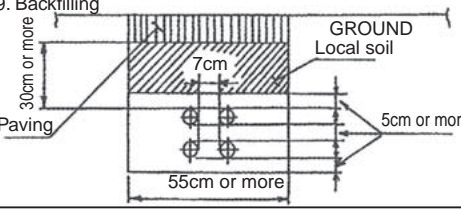

Installation diagrams	Procedures and points to note	Caution
<p>6. Backfilling (first tier)</p> 	<ol style="list-style-type: none"> (1) Throw in the sand quietly using heavy equipment or other means, principally onto the sand used for provisional fixing. (2) Level the sand using a scoop. (3) Compact the sand beside the pipe using a tamping rod. (4) Compact the sand using a compactor, as in procedure 2. 	<ol style="list-style-type: none"> (1) Confirm that mortar has hardened after treating the wall surface. (2) Compact the sand with special care around the manhole, using a tamping rod.
<p>7. Test rod passing</p> 	<ol style="list-style-type: none"> (1) Pass the prescribed test rod through, to confirm that the pipe has been laid normally. 	<ol style="list-style-type: none"> (1) If there was any portion that prevented the test rod from passing through, excavate around the spot again and correct the abnormality in the pipe, and perform the test again.
<p>8. Working on the second tier</p>	<p>Repeat the procedures 3 to 7.</p>	
<p>9. Backfilling</p> 	<ol style="list-style-type: none"> (1) Fill in the local soil with heavy equipment for the depth of about 30cm. (2) Level the surface using a scoop. (3) Compact the local soil sufficiently using a tamping rammer. (4) Repeat the processes (1) to (3), to reach the bottom surface of pavement. 	
<p>10. Others</p>		<ol style="list-style-type: none"> (1) If EFLEX is laid as a spare pipe, be careful of leaking water and provide the edge treatment.

5 Cautions when Drawing in the Cables

5-1. Drawing in of Cables

Attach a bellmouth at the end of EFLEX that has been laid, and the switch pilot wire that has already been inserted inside EFLEX with the wire for drawing in the cables, and then draw in the cables.

5-2. Sizes of EFLEX and Cables

(1) Electrical cables

The inner diameter of EFLEX should be 1.5 times or more of the finished outer diameter of a cable when one cable is laid, and 1.5 times or more the diameter of circumscribed circle around the bundled cables, when two or more cables are laid.

(2) Telecommunication cables

Double or more the finished outer diameter of the cable, and double or more the diameter of a circumscribed circle around the bundled cables if two or more cables are laid.

6 Special Construction Method

6-1. Concrete covering method

When EFLEX is covered with concrete for laying at a shallow depth and other reasons, please note the following. We have "KOHTA KUN", a porous pipe made of synthetic resin, available for burying at shallow depths.

CAUTION

- (1) Since EFLEX is lightweight and void, it could float inside the concrete and become disarranged and meander vertically, affecting the wiring work. Therefore, fix EFLEX with reinforcement rods of diameters of 10mm or more, for about every 50cm of EFLEX.
- (2) When casting concrete, do not let the concrete come into direct contact with EFLEX (to prevent damage) but let the concrete flow in slowly without being injected at once in large quantity. Make sure that the concrete has spread sufficiently around EFLEX.
- (3) Be sure to pass the test rod before and after casting concrete, to confirm the conditions of construction work and the inside of the pipe.
- (4) Never use spring buckle for the concrete section, as it functions in the same way as pipe saddles.





7 Methods for Repair

7-1. Methods for Repair

(1) Provide the standard repairs shown in Table 6 when EFLEX is damaged.

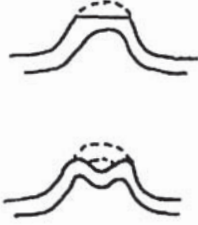
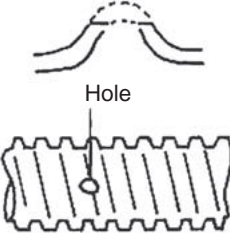
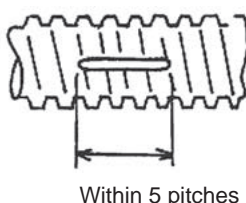
Table 6 : Level of Damage and Methods for Repair

Class	Conditions	Level of damage	Repairing method	Materials used
A (Light)		The peak of corrugation was chipped off to about half the wall thickness, or a dent formed in the peak section within one pitch.	The pipe may be used as is, as a rule, but it is better to provide repairs for B or C if the environment for use are severe.	
B (Medium)	 Hole	A hole was pierced through the peak section, or a hole of a size of one pitch was made by a pickaxe or a pile.	Wrap with EFLEX VUL-CO tape halfway for two round trips, for three or more pitches around the damaged point.	EFLEX VUL-CO PVC tape
C (Heavy)	 Within 5 pitches	Continuous hole pierced for five pitches or less	Split a straight connection sleeve in two and cover the damaged portion, wrap the sealing tape around the boundary and the split edge. Then, cover the sleeve with EFLEX VUL-CO halfway for two round trips.	A set of straight connecting material Sealing tape
D (Serious)	 Rupture	EFLEX has totally ruptured. The original form is not intact.	(Before inserting cable) Cut and remove the damaged portion and replace with a good one, and provide a straight connection.	Two sets of EFLEX straight connection materials
			(After inserting cable) *As per split VP pipe method	Split VP pipe Two bellmouths Epoxy putty EFLEX VUL-CO PVC tape Tying lines

The above damage would not result if EFLEX was handled normally.

***Procedures for split VP pipe method**

- (1) Cut out the damaged portion without damaging the cables inside the pipe.
- (2) Clear all dirt on both cut edges of EFLEX with a wipe cloth or similar.
- (3) Fit the split bellmouth into both cut edges of EFLEX.
- (4) Apply epoxy putty to the circumference at the mouth of EFLEX and at a location 150mm away from the mouth.
- (5) Place epoxy putty on the top and bottom of the split VP pipe and then cover the pipe. After fastening with a stainless hose band, apply epoxy putty to the circumference at the mouth of the VP pipe.
- (6) Cover the entire repaired length with ELFLEX VUL-CO halfway, for one round trip. Wind PVC tape over to cover the edge.

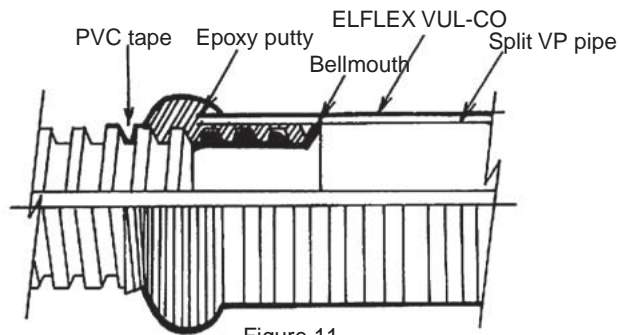

Figure 11

CAUTION Purchase VP pipe separately.

Refer to the table below for the amount of materials used when the length to be repaired is 1m.

Table 7

Size of ELFLEX		φ 30	φ 40	φ 50	φ 65	φ 80	φ 100	φ 125	φ 150	φ 200
Materials used	Split VP pipe	VP 50	VP 65	VP 75	VP 100	VP 125	VP 150	VP 200	VP 250	VP 300
	Size of original pipe	VP 50	VP 65	VP 75	VP 100	VP 125	VP 150	VP 200	VP 250	VP 300
	Length (m)	1	1	1	1	1	1	1	1	1
	Quantity (pipes)	1	1	1	1	1	1	1	1	1
	Bellmouth (quantity)	2	2	2	2	2	2	2	2	2
	Epoxy putty (kg)	0.5	1.0	1.0	2.0	3.0	4.0	8.0	14.0	17.0
	ELFLEX VUL-CO (rolls)	2	3	3	4	5	6	8	10	12
PVC tape (rolls)	1	1	1	1	1	1	1	1	1	

Material specifications

ELFLEX VUL-CO: 1.0mm in thickness, 40mm in width and 10m in length

PVC tape: 0.2mm in thickness, 19mm in width and 10m in length

(2) Treatment after repair

The civil engineering work for the repaired section is performed as shown in Figure 12.

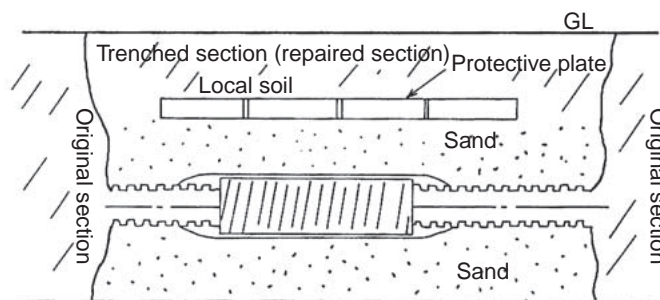

Figure 12

CAUTION (1) Make sure to compact the sand well around the repaired section.
 (2) Sufficiently compact the sand underneath EFLEX.

7 – 2. Handling of Lost Pilot Wire Inside the Pipe

If the pilot wire becomes lost in the pipe while treating the mouth of EFLEX, provide the following procedures:

- (1) Insert a wire (straight) with the edge bent in a U-shape from the mouth from which the pilot wire got lost, until the wire overlaps with the pilot wire for two or three meters. If the length of wire is not sufficient, connect the additional wire to make up for the deficiency at the mouth on the other end.
 - (2) Bend the wire in an L-shape at the mouth, and rotate the wire like a handle. This causes the wires to get tangled with each other.
 - (3) If the wires seem to have tangled, pull out the wire. If the wires fall apart while pulling out, insert the wire again and repeat the procedures.
- If the length of the pilot wire that became lost in the pipe exceeds 20m, insert a rod.

CAUTION Be very careful when handling wires. Wear protective goggles when working.

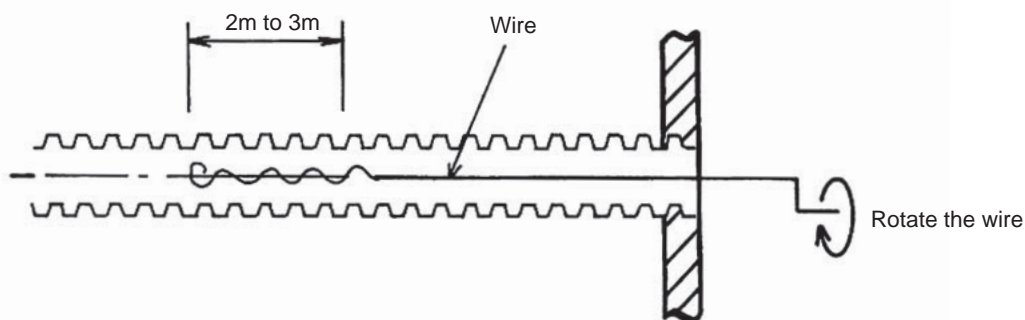

Figure 13

8 Other Cautions

- (1) In places where damages could occur, such as locations that may be excavated erroneously, protective plates (Furukawa EFLITE) or buried object indication tape may be installed at interval halfway between the surface and the depth where EFLEX is buried.
- (2) When installing EFLEX, never use the saddles (spacers) for fixing or maintaining intervals between them, as with other cable conduits.
- (3) Use buffer pipe for EFLEX when attaching EFLEX to the wall surface of the manhole (hand hole, building, etc.), at locations afflicted with severe land subsidence.
- (4) The bending radius of EFLEX is usually set at 10 times or more the outer diameter. However, the minimum value could be five times the outer diameter or more, within a scope that will not affect cables.
- (5) If cables are not drawn in for a long time after installing EFLEX, replace the pilot wire with order line (plastic order line) to replace EFLEX.

Working with Aquafit, a Straight Joint for EFLEX



Please follow the procedures below when working with Aquafit, a straight joint for EFLEX.

1. Materials for Aquafit, a straight joint for EFLEX



Set of materials
Aquafit

Tools used
Belt wrench (ϕ 125 to ϕ 200)

2. Work procedures

1

- Measure half the length of Aquafit.
- Mark on EFLEX at the location by measuring the above length from the edge.
- Screw in Aquafit until the edge aligns with EFLEX.

CAUTION Use of tools such as a belt wrench enables smoother work with ϕ 125 to ϕ 200.

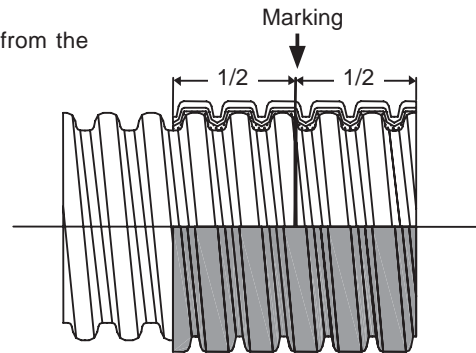

2

- Place two edge face of EFLEX face-to-face.

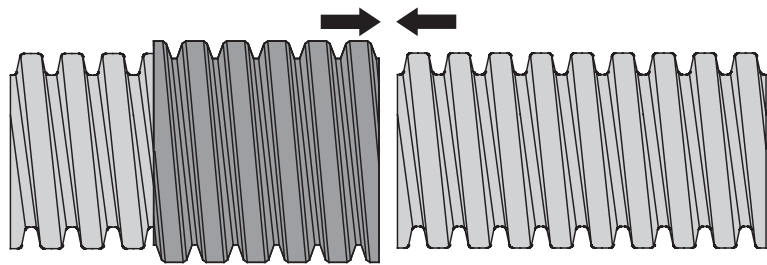

3

- Rotate Aquafit that has been screwed into EFLEX on one side in the opposite direction to the marking position, so that the position where EFLEX meets face-to-face (edge face) comes to the center of Aquafit.

CAUTION

- Do not take out from the bag until immediately before use, to protect the moisture-absorbing fiber.
- Wipe off the water and mud from the surface of EFLEX well before connecting the joint.
- Do not use at construction sites where a large volume of water has penetrated inside EFLEX.

Diagram of finished joint

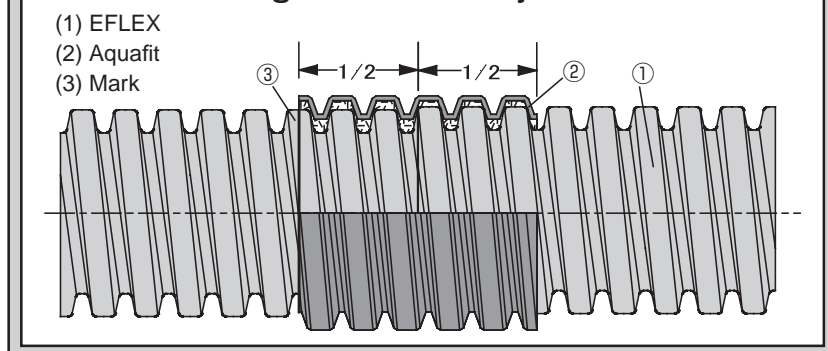

Working with Epoxy Putty for EFLEX (Waterproof wall sealing compound)



Follow the procedures below when working with epoxy putty (waterproof wall sealing compound) for EFLEX.

1. Epoxy putty material



Set of materials
(1) Main agent (black)
(2) Hardening agent (white)

2. Work procedures

- 1 Mix the main agent and hardening agent of epoxy putty in a ratio of 1:1.



- 2 Mix the hardening agent and main agent completely, until the mixture turns gray.



CAUTION

- Wear the gloves attached when working.
- Users with allergies might feel stimulus on the skin, so avoid touching the putty directly.
- The epoxy starts hardening soon after mixing (in about 30 minutes), so mix the amount to be used each time.
- Sprinkle a small amount of water when it is hard to mix the putty. For EPOAL, immerse in warm water entirely with the bag and use it after it is heated and softened.
- Wipe off moisture with waste cloth, if attached to a manhole (hand hole) or wall surface (concrete or similar).

Working with Waterproof Wall Sealing Compound (EFLEX)

Follow the procedures below when working with waterproof wall sealing compound (EFLEX).

1. Materials for EFLEX waterproof wall sealing compound

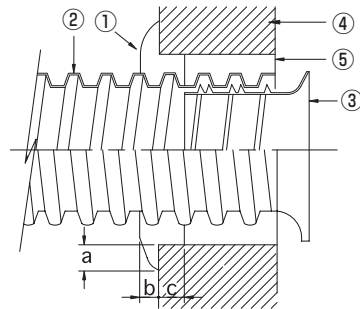

Set of materials

- (1) Epoxy putty (waterproof wall sealing compound)
- (2) EFLEX
- (3) Bellmouth
- (4) Manhole (hand hole)
- (5) Mortar

2. Work procedures

1 Refer to the table below for the amount of epoxy putty to be applied to wall openings.

Dimensions of epoxy putty to be applied

Nominal diameter of EFLEX	a (mm)	b (mm)	c (mm)
φ30 to φ100	20	10	20
φ125 or more	20	10	30

Amount of epoxy putty used and wall opening diameter

EFLEX		Opening on wall surface (approx. mm)	Amount of epoxy putty used (kg)
Size	Outer diameter (approx. mm)		
φ 30	40	80	0.5
φ 40	54	100	0.5
φ 50	65	110	0.5
φ 65	85	130	1.0
φ 80	102	160	1.0
φ 100	130	180	1.5
φ 125	160	210	2.0
φ 150	189	260	4.0
φ 200	253	310	5.5

2 Insert EFLEX through the wall opening

3 After putting waste cloth and other materials into EFLEX to prevent mortar from getting in, fill in the mortar while supporting EFLEX at the center of the opening.

4 After removing the waste cloth, attach a bellmouth to the edge of EFLEX.

5 Apply epoxy putty.

CAUTION

When aligning a wall opening with EFLEX, use panels or similar for better results.

 **THE FURUKAWA ELECTRIC CO., LTD.**

Industrial Products Division, Energy & Industrial Products Company <http://www.furukawa.co.jp/eflex/>

Head Office 2-3, Marunouchi 2-chome, Chiyoda-ku, Tokyo, 100-8322 TEL.81-3-3286-3195 FAX.81-3-3286-3454

Engineering & Development Department 1-9, 5-chome, Higashiyawata, Hiratsuka, Kanagawa, 254-0016 TEL.81-463-24-8351 FAX.81-463-24-8347