

Series 09

Rugged CAN Keypads

Rugged. Modular. Reliable.

www.eao.com



Series 09 Rugged CAN Keypads

CAN Modules – Rugged. Modular. Reliable.

Designed for E1 applications with functional safety and CAN bus integration – The robust control units with flexible illumination are ideally suited for use in heavy duty and special vehicle applications.

Series 09 Rugged CAN Keypads offer high reliability: The modules are designed for E1 applications and functional safety in accordance with ISO 26262 ASIL B and EN ISO 13849 PLD as well as an intelligent control with CAN bus integration. The robust, modular design with sealing levels of up to IP67 and the ability to customise and interchange the keypad legends make these high-quality devices ideally suited for harsh use in heavy duty and special vehicles.

High reliability and functional safety are crucial to controlling safety-related applications in vehicles and machines – whether in construction machinery, construction vehicles, agricultural machinery or in special and commercial vehicles of various types. Harsh environments and low back panel depth require a robust and compact product design. The actuators and indicators must also be precisely configured, both mechanically and electronically, to suit the respective application. The high-quality Rugged CAN Keypad and Rugged CAN Rotary Cursor Controller meet these requirements with cutting-edge system integration.

Robust, innovative design

Robust and innovative construction is a feature of the Rugged CAN Keypads design. The up to IP67 protected actuators and indicators work reliably at operating temperatures from –40 °C to +85 °C. The low back panel depth and ro-

bust clip-in or screw-in mounting allow easy, flexible installation, either vertically or horizontally. These high-quality devices also offer excellent tactile feedback, and are clearly visible in daylight and at night thanks to the powerful RGB LED halo and LED symbol illumination. Attractive and configurable 4-segment halo button illumination is integrated as standard. The customisable illumination provides the operator with excellent visual feedback, and is combined with a unique, contemporary design.

Durability

The Series 09 CAN Modules are produced in our automotive competence centre located in Germany. This allows us to apply years of comprehensive experience as an original equipment manufacturer (OEM) in the automotive industry to the heavy duty and special vehicle markets. At the same time, this offers EAO customers high quality, durable, and intuitive products and services. The development and production process is aligned and executed according to automotive standards that include qualified suppliers and functional safety. This requirement ensures EAO customers high quality products and solutions.

Functional safety and CAN bus integration

The Rugged CAN Keypads feature a high reliability and are designed for functional safety in accordance with the EN ISO 13849 PLD and ISO 26262 ASIL B standards. Put simply, functional safety means that the system monitors whether the safety-related function is working properly. If a function error occurs, the system promptly informs the operator. Thanks to the CAN bus integration, the devices are intelligently and easily integrated into a CAN system – the devices are fitted with a Deutsch DT Series connector.

More than an expert. A partner of the automotive industry.

As a global partner to major automotive manufacturers and suppliers, we provide our customers with high-quality, products and services. Through many decades of commitment and consultation with the automotive industry, EAO is an established global supplier of operator control panels, sub-assemblies, switches, buttons and indicators.

Please note

Functional safety with CANopen Safety and ASIL B according to ISO 26262 and PLD according to DIN EN ISO 13849 are available from 2020 onwards.

Advantages.

- Individual 4-segment and RGB halo ring illumination
- Designed for functional safety: ISO 26262 and ISO 13849
- Intelligent HMI with CAN bus integration
- Robust, innovative, ergonomic design sealed up to IP67 protection
- Interchangeable ISO 7000 range of symbols or customised symbols

Typical applications

- Special vehicles including fire-fighting vehicles, road sweepers, cleaning vehicles, refuse trucks, snow removers and groomers
- Heavy duty vehicles including construction and agricultural equipment

HMI functions

- Rugged CAN Keypad
- Rugged CAN Rotary Cursor Controller

Mechanical characteristics

- Actuating force: 5-13 N
- Overload: 250 N
- Service life
 - Rugged CAN Keypad: up to 1 million switching cycles
 - Rugged CAN Rotary Cursor Controller: up to 10 million switching cycles

Electrical characteristics

- Operating voltage range: 8-32 VDC

Illumination

- LED symbol illumination
 - Colour: white LED
 - Luminance: 20 cd/m²
- LED halo ring illumination
 - Colour: RGB
 - Luminance: 1 500 cd/m²

Symbols

- Symbols in accordance with ISO 7000
- Customer-specific symbols on request

Connections/interfaces

- CAN interface (ISO 11898)
- CAN protocols: CANopen (CiA 401), CANopen Safety* (EN 50325-5), CAN J1939
- Baud rate 250 kBd (software configurable)

* Functional safety with CANopen Safety protocol available as of 2020.

Ambient conditions

- Operating temperature: –40 °C ... +85 °C
- Storage temperature: –40 °C ... +85 °C

Protection degree

- IP67 protection (front and rear side)
- IP67 protection (panel/screw-in)
- IP54 protection (panel/clip-in)

Examples of unit combinations

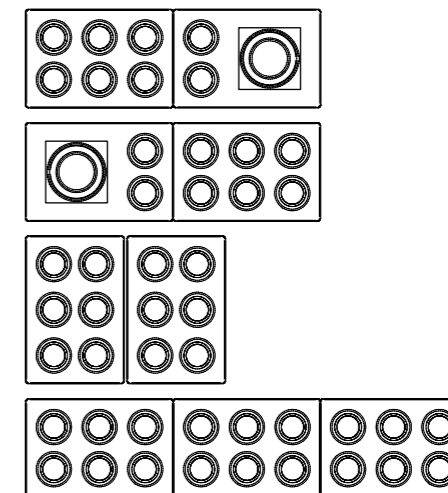

Further information is available under www.eao.com/09

Features and benefits.



Sealing protection

Robust, resistant to weather and harsh environments, IP67 seals out dust, water, mud, salt, sand, oil

Symbols

Interchangeable inserts with laser etch LED backlit ISO 7000 range of symbols or customised symbols

Mounting option

Flexible vertical and horizontal installation as well as user-friendly clip-in and screw-in mounting

Illumination

Modern, trendy, innovative RGB 4-segment halo ring illumination in unlimited variety of colours and visual effects

Modularity

Control units can be combined into array of modules

Safety level

Designed for functional safety*: ISO 26262 and ISO 13849

Communication protocols

Intelligent HMI with J1939, CANopen and CANopen Safety* integration

Design

Smart, optimally ergonomic design with low panel depth mounting

Feedback

Tactile and audible product feedback with haptic design

* Functional safety with CANopen Safety and ASIL B according to ISO 26262 and PLD according to DIN EN ISO 13849 are available from 2020 onwards.

Approvals and conformities.*

Test	Standard	Load
Mechanical specifications (acc. ISO16750-3: mounting location codes D, E, F, G, K, L, R, S)		
Vibration	ISO 16750-3 4.1	Test IV and Test VII
Tests for devices on doors or flaps	ISO 16750-3 4.2.1	half-sinusoidal, 300 m/s ² , 6 ms, 100.00 shocks
Tests for devices on rigid points on the body and on the frame	ISO 16750-3 4.2.2	half-sinusoidal, 500 m/s ² , 6 ms, 10 shocks per direction
Drop test	ISO 16750-3 4.3	height: 1 m, 6 directions (±x, ±y, ±z), 2 falls per DUT (±direction)
Surface strength/scratch and abrasion resistance	ISO 16750-3 4.4	ASTM F2357-10
Impact resistance	IEC 62262	IK07, 2 Joules, free-fall hammer
Environmental specifications (acc. ISO16750-4: temperature code G, climatic load code H)		
Low-temperature storage test	ISO 16750-4 5.1.1.1	-40 °C, 24 h
High-temperature storage test	ISO 16750-4 5.1.2.1	+95 °C, 48 h
Low-temperature operation test	ISO 16750-4 5.1.1.2	-40 °C, 24 h
High-temperature operation test	ISO 16750-4 5.1.2.2	+85 °C, 96 h
Temperature step test	ISO 16750-4 5.2	Tmin = -40 °C, Tmax = +85 °C
Temperature cycle with specified change rate	ISO 16750-4 5.3.1	Tmin = -40 °C, Tmax = +85 °C, Profile Tab. 2, 30 cycles (each 480 min)
Rapid change of temperature with specified transition duration	ISO 16750-4 5.3.2	Tmin = -40 °C, Tmax = +85 °C, 100 cycles
Ice water shock test - Splash water test	ISO 16750-4 5.4.2	Tmax = +85 °C, 100 cycles
Ice water shock test - Submersion test	ISO 16750-4 5.4.3	Tmax = +85 °C, 10 cycles
Salt spray test - Corrosion test	ISO 16750-4 5.5.1	T = 40 °C, 5 % sodium chloride solution, pH-Value 6.5-7.2, severity 4, 2 cycles (each 10 days)
Salt spray test - Leakage and function test	ISO 16750-4 5.5.2	T = 35 °C, 5 % sodium chloride solution, pH-Value 6.5-7.2, 6 cycles (each 24 h)
Composite temperature/humidity cyclic test	ISO 16750-4 5.6.2.3	Tmin = -10 °C, Tmax = 65 °C, 95 % RH, 10 cycles (each 24 h)
Dewing test	ISO 16750-4 5.6.2.4	Tmax = 80 °C, 95 % RH, 5 cycles (300 min)
Damp heat, steady-state test	ISO 16750-4 5.7	(40 ± 2) °C, (80 ± 3) % RH, 21 days
Corrosion test with flow of mixed gas	ISO 16750-4 5.8	IEC 60068-2-60, test Ke, method 4, 21 days
Solar radiation	ISO 16750-4 5.9	ISO 4892-2, method A, cycle no. 1
Protection against dust and water	ISO 16750-4 7	IP67 according ISO 20653
Electromagnetic specification		
Chemical resistance	ISO 16750-5	Chemical load codes: AD, CA, CD, CE, CF, CG, DA, DB, DC, DD, DE, DF, DG, DJ, DK, EA, EB, EC, ED, EE, EF

Test	Standard	Load
Electromagnetic compatibility tests (acc. ISO16750-2: supply voltage code min. B, max. F)		
Electrostatic discharge (ESD)	ISO 10605 8	powered-up, up to ± 15 kV, 10 pulses
Electrostatic discharge (ESD)	ISO 10605 9	unpowered, up to ± 15 kV, 10 pulses
Electromagnetic disturbances (conducted)	DIN EN 55025 6.3	
Electromagnetic disturbances (radiated emissions)	DIN EN 55025 6.4	
	ISO 11452-2	200 MHz to 3.2 GHz, 100 V/m, 66.7 mA to 200 mA, severity level IV
	ISO 11452-4	1 MHz to 400 MHz, 66.7 mA to 200 mA, severity level IV
	ISO 11452-5	10 kHz to 400 MHz, 200 V/m, severity level IV
	ISO 11452-8	15 Hz to 30 kHz, 10 A/m to 600 A/m
	ISO 11452-9	26 MHz to 5.85 GHz, 1 W to 10 W
Electrical specifications (acc. ISO16750-2: supply voltage code min. B, max. F)		
Direct current supply voltage	ISO 16750-2 4.2	8 V ... 32 V
Overvoltage	ISO 16750-2 4.3	36 V, 60 min
Superimposed alternating voltage	ISO 16750-2 4.4	U _{max} = 36 V, U _{pp} = 4 V, 50 Hz - 20 kHz
Slow decrease and increase of supply voltage	ISO 16750-2 4.5	U _{max} = 32 V, U _{min} = 0 V, 1 V/min
Momentary drop in supply voltage	ISO 16750-2 4.6.1	U _{Smin} = 8 V, U _{min} = 4.5 V, t = 100 ms
Reset behaviour at voltage drop	ISO 16750-2 4.6.2	U _{Smin} = 8 V, U _{min} = 0 V, thold_drop = 5 s
Starting profile	ISO 16750-2 4.6.3	U _N = 12 V severity level II, U _N = 24 V severity level II,
Reverse voltage	ISO 16750-2 4.7	-28 V, 60 s
Ground reference and supply offset	ISO 16750-2 4.8	28 V, offset 1 V
Single line interruption	ISO 16750-2 4.9.1	28 V, interruption 10 s
Multiple line interruption	ISO 16750-2 4.9.2	28 V, interruption 10 s
Short circuit protection	ISO 16750-2 4.10	32 V, R _{i PSU} < 100 mOhm, 60 s
Electrical transient conduction along supply lines	ISO 7637-2	Test pulses 1, 2a, 2b, 3a, 3b with severity level III
Electrical transient transmission by capacitive and inductive coupling via lines other than supply	ISO 7637-3	CCC test severity level IV ICC test severity Level III
Lifetime test		
Mechanical lifetime		1 million actuations per key 10 million detents (rotation rotary cursor controller) 10 million actuations (joystick rotary cursor controller)

* Available as of 2020.

Rugged CAN Keypad.



Mechanical characteristics

- Actuation force: 5–13 N
- Overload: 250 N

Electrical characteristics

- Operating voltage range: 8–32 VDC

Illumination

- LED symbol illumination
 - Colour: white
 - Luminance: 20 cd/m²
- LED halo ring illumination
 - Multi-colour: RGB
 - Luminance: 1500 cd/m²

Symbols

- Symbols in accordance with ISO 7000
- Customer-specific symbols on request

Connections/interfaces

- CAN interface (ISO 11898)
- CAN protocols: CANopen (CiA 401), CANopen Safety* (EN 50325-5), CAN J1939
- Baud rate 250 kBd (software configurable)

Ambient conditions

- Operating temperature: –40°C ... +85°C
- Storage temperature: –40°C ... +85°C

* Functional safety with CANopen Safety protocol available as of 2020.

Protection degree

- IP67 protection (front and rear side)
- IP67 protection (panel/screw-in)
- IP54 protection (panel/clip-in)

Dimensions (All dimensions in mm)

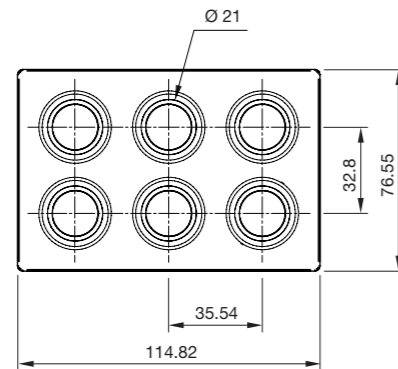

Mounting cut-out (Panel thickness 1.0 mm ... 4.0 mm)

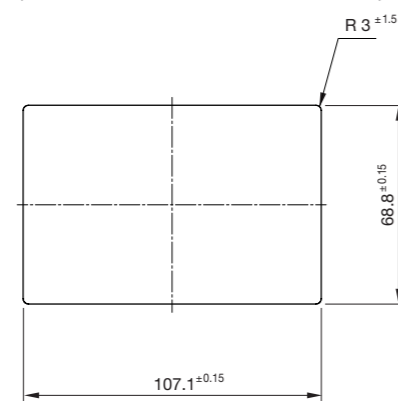

Mounting Clip-in mounting

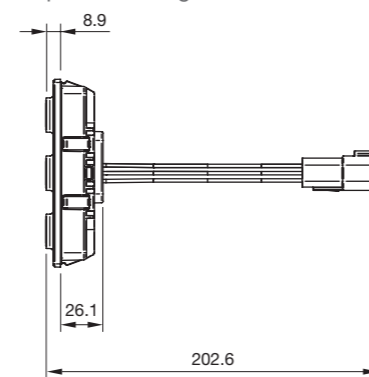

Screw-in mounting

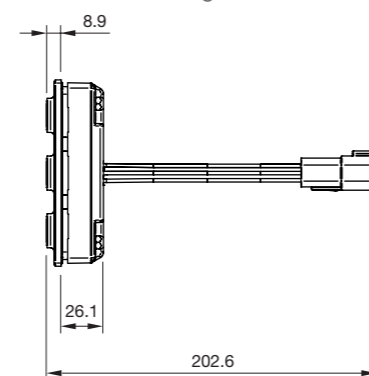

Rugged CAN Rotary Cursor Controller.



Function variants (any combination possible)

- Joystick function
 - With/without joystick function
 - Proportional Hall effect sensor output signal
 - x/y guidance is optional with
 - strong/rigid cross guidance – x and y direction only
 - soft cross guidance – freely movable with soft x/y guidance
 - no cross guidance – freely movable
- Rotary function
 - With rotary function
 - 20 maintained positions
 - Continuous rotation with no stop position
- Push function
 - With/without push function
 - Momentary action with click-dome

Mechanical characteristics

- Overload: 250 N
- Service life of up to 250 000 cycles of operation
- Momentary action
 - Actuation force: 5-13 N
- Rotary function
 - Haptic with precise detent
- Joystick function
 - Actuation angle: ~10°

Electrical characteristics

- Operating voltage range: 8–32 VDC

Illumination

- LED symbol illumination (on pushbuttons)
 - Colour: white
 - Luminance: 20 cd/m

- LED halo illumination (on pushbuttons and Rotary Cursor Controller)
 - Multi-colour: RGB
 - Luminance: 1500 cd/m²

Symbols (on pushbuttons, Rotary Cursor Controller without symbol)

- Symbols in accordance with ISO 7000
- Customer-specific symbols on request

Connectivity

- CAN interface (ISO 11898)
- CAN protocols: CANopen (CiA 401), CANopen Safety* (EN 50325-5), CAN J1939
- Baud rate 250 kBd (software configurable)

Ambient conditions

- Operating temperature: –40°C ... +85°C
- Storage temperature: –40°C ... +85°C

Protection degree

- IP67 protection (front and rear side)
- IP67 protection (panel/screw-in)
- IP54 protection (panel/clip-in)

* Functional safety with CANopen Safety protocol available as of 2020.

Dimensions (All dimensions in mm)

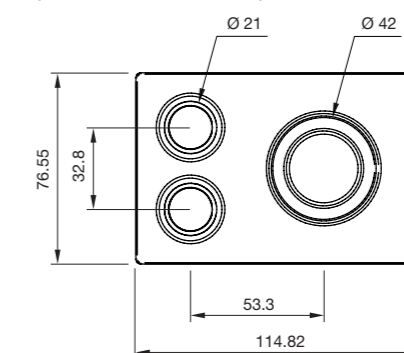

Mounting cut-out (Panel thickness 1.0 mm ... 4.0 mm)

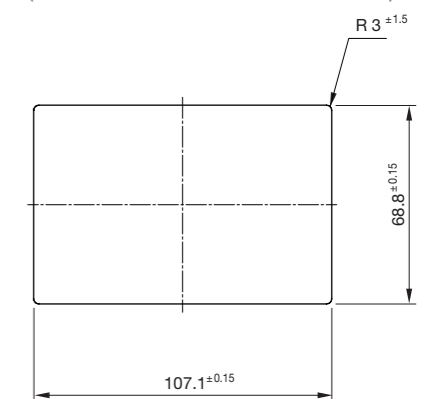

Mounting Clip-in mounting

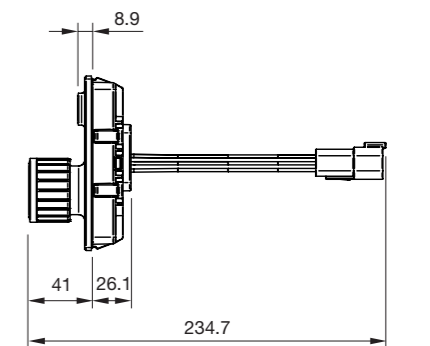

Screw-in mounting

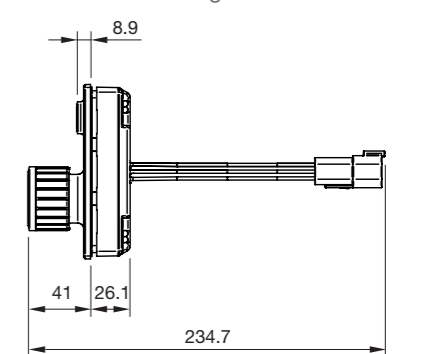

Deutsch DT Series connector (DT04-6P).

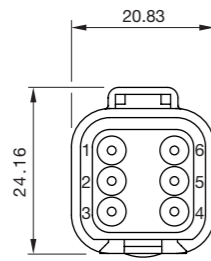
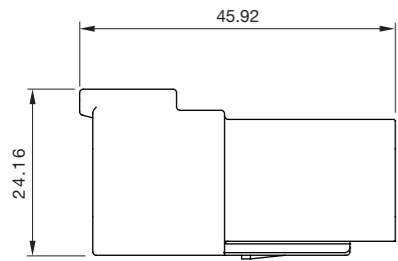
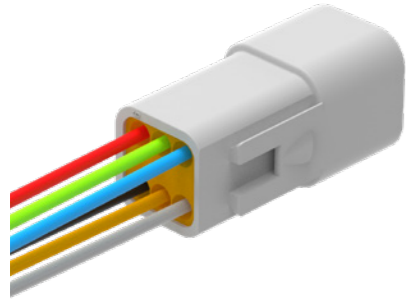

Pin	Signal
1	GND
2	CAN High
3	WakeUp_Out
4	WakeUp_In
5	CAN low
6	Vcc

Mates with Deutsch DT06-6S-****

All dimensions in mm.

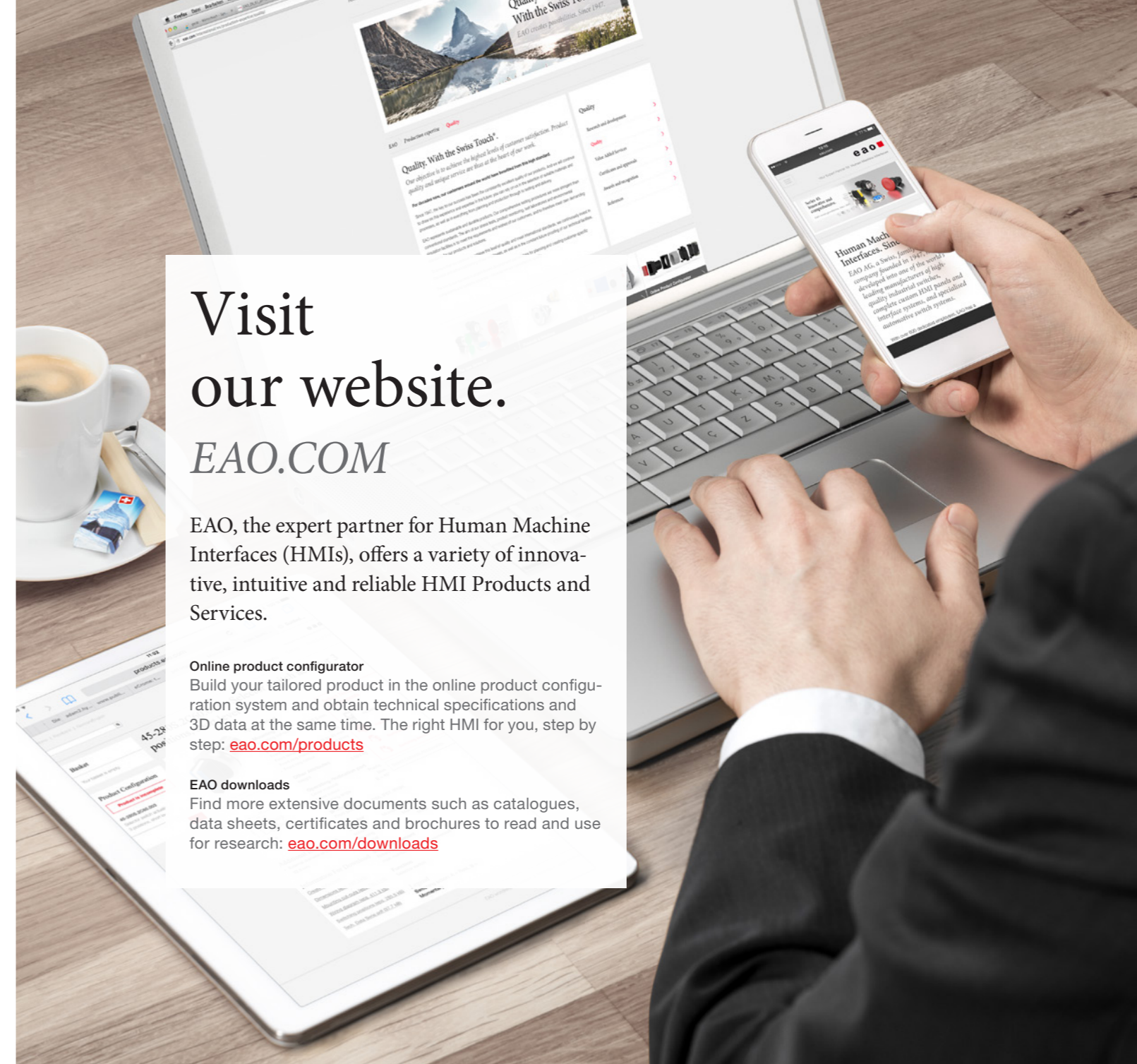

Visit our website.

EAO.COM

EAO, the expert partner for Human Machine Interfaces (HMIs), offers a variety of innovative, intuitive and reliable HMI Products and Services.

Online product configurator

Build your tailored product in the online product configuration system and obtain technical specifications and 3D data at the same time. The right HMI for you, step by step: eao.com/products

EAO downloads

Find more extensive documents such as catalogues, data sheets, certificates and brochures to read and use for research: eao.com/downloads

Related documents

Find out more about our innovative, intuitive and reliable HMI Products and Solutions.

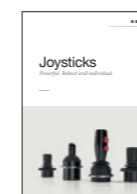

Series 09
Brochure

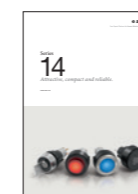

Series 14
Brochure

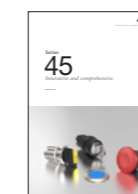

Series 45
Brochure



Series 61
Brochure



Series 82
Brochure

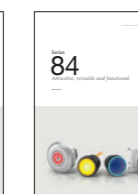

Series 84
Brochure

EAO Contact.

Your centre of excellence.

Headquarters

EAO Holding AG
Tannwaldstrasse 88
CH-4600 Olten
Telephone +41 62 286 92 00
info@eao.com

Manufacturing Companies

Switzerland
EAO AG
Tannwaldstrasse 88
CH-4600 Olten
Telephone +41 62 286 91 11
info@eao.com

EAO Systems AG
Tannwaldstrasse 88
CH-4600 Olten
Telephone +41 62 286 91 11
sales.esy@eao.com

China
EAO (Guangzhou) Ltd.
3/F, Block G4, South China
New Materials Innovation Park
31 Kefeng Road
Guangzhou Science City
CN-Guangzhou, PRC
Telephone +86 20 3229 0390
sales.ecn@eao.com

Germany
EAO Automotive GmbH & Co. KG
Richard-Wagner-Straße 3
DE-08209 Auerbach/Vogtland
Telephone +49 3744 8264 0
sales.esa@eao.com

North America
EAO Corporation
One Parrott Drive
Shelton
US-CT 06484
Telephone +1 203 951 4600
sales.eus@eao.com

Sales Companies

China
EAO (Guangzhou) Ltd.
3/F, Block G4, South China
New Materials Innovation Park
31 Kefeng Road
Guangzhou Science City
CN-Guangzhou, PRC
Telephone +86 20 3229 0390
sales.ecn@eao.com

EAO (Shanghai) Office
Rm.401, Lihpao Plaza,
NO.159 Shenwu Road,
Minhang District,
CN-Shanghai, 201106.
PRC
Telephone +86 21 6095 0717
sales.ecn@eao.com

France
EAO France SAS
Nextdoor – Bâtiment Silex
15 rue des Cuirassiers
CS 33821
FR-69487 Lyon Cedex O3
Telephone +33 9 74 18 93 41
sales.eifr@eao.com

**Germany, Austria, Czech Republic,
Poland, Slovakia**
EAO GmbH
Langenberger Straße 570
DE-45277 Essen
Telephone +49 201 8587 0
sales.ede@eao.com

Hong Kong (Asia Pacific)
EAO (Far East) Ltd.
Unit A1, 1/F, Block A
Tin On Industrial Building
777 Cheung Sha Wan Road
Lai Chi Kok, Kln
HK-Hong Kong
Telephone +852 27 86 91 41
sales.ehk@eao.com

Italy
EAO Italia S.r.l.
Centro Direzionale Summit –
Palazzo D1
Via Brescia 28
IT-20063 Cernusco sul Naviglio (MI)
Telephone +39 029 247 0722
sales.eit@eao.com

Japan
EAO Japan Co. Ltd.
Net 1 Mita Bldg. 3F
3-1-4 Mita Minato-ku
JP-Tokyo 108-0073
Telephone +81 3 5444 5411
sales.ejp@eao.com

Netherlands, Belgium
EAO Benelux B.V.
Kamerlingh Onnesweg 46
NL-3316 GL Dordrecht
Telephone +31 78 653 17 00
sales.enl@eao.com

North America
EAO Corporation
One Parrott Drive
Shelton
US-CT 06484
Telephone +1 203 951 4600
sales.eus@eao.com

Switzerland
EAO Schweiz AG
Tannwaldstrasse 86
CH-4600 Olten
Telephone +41 62 286 95 00
sales.ech@eao.com

**United Kingdom, Denmark,
Finland, Ireland, Norway, Sweden**
EAO Ltd.
Highland House
Albert Drive
Burgess Hill
GB-West Sussex RH15 9TN
Telephone +44 1444 236 000
sales.euk@eao.com